

Offshore

i n d u s t r y

Well Enhancer

VERSATILE ASSET FOR HELIX

Pipe Pulling

PIPELINE SHORE APPROACHES

Sakhalin II

RUSSIAN ENERGY ONSTREAM

Underwater Repairs

ACCOMPLISHING THE IMPOSSIBLE



Superlite Superstructures



Photo courtesy of Statoil Hydro

The Triplate Transition Joint

The vacuum-explosion welded transition joint called Triplate is a high quality material for welding aluminium to steel. Triplate does not only find its application in the shipbuilding industry, but also in the construction of offshore topside structures. The mechanical properties of welding aluminium to steel revealed.



For quite a number of years now, shipbuilders and engineering companies have gratefully taken advantage of the availability of pre-produced transition joint assemblies to make welds between aluminium and steel. The older, more traditional methods of joining, like riveting and bolted joints have fallen from favour due to the fact that in a few years considerable corrosion can occur aided by capillary action caused mainly by the widely differing thermal expansion coefficients of aluminium and steel. In spite of efforts to prevent it, this phenomenon allows seawater to seep into the dissimilar metal joint, thereby resulting in severe corrosion. In many cases the only way to maintain a ship in a seaworthy condition is to completely replace the aluminium-steel transition or, in some cases, to replace the complete wheelhouse.

Cladding Process

Transition joints were mainly produced by the explosive weld-bonding process carried out in the open air in remote locations. This explosive process is in fact a cold pressure welding process, where investigations have shown that superior joint properties can be achieved if the process takes place under vacuum. The following deals with what actually happens during the explosive bonding process. An empirically calculated stand-off space between two plates to be bonded is created by placing polystyrene blocks between them. Thus the upper plate is accelerated down onto the lower plate during the explosion. The velocity varies with the type and the quantity of explosive material used and the weight of the upper plate. It is most important that the stand-off distances are equal. At the collision point, an extremely high pressure is reached during the explosion, which causes the metal surfaces to become super-plastic enabling the pressure wave to break up the oxide surfaces. These oxide particles are driven out of the advancing detonation front, together with the air to produce the so-called jet. The result is that the two metal surfaces are pressed together with huge force, locally

interlocking the different atomic structures. In this way, by definition, a very strong atomic bond is formed between two metals like aluminium and steel. After the cladding process the plates are flattened and then sawn into strips which are used as an intermediate layer for welding aluminium alloy superstructures to steel hulls. As these aluminium-magnesium alloys are too hard to form a strong explosive bond with the steel, a softer commercially pure aluminium sheet is positioned in the sandwich layer between them, which gives us the name Triplate.

Atmospheric or Vacuum Cladding

Although atmospheric cladding is an effective process, there appear to be advantages if the explosive bonding process is carried out under vacuum. Apart from the fact that the vacuum process does not cause 'noise nuisance', its greatest advantage is that it is not necessary to remove any air in the advancing, explosive-

Dimensions

Standard dimensions are available from stock; custom-made sections can also be supplied quickly (including water-jet cutting). The recommended stripwidth is 4 x thickness of the aluminium plate.

Standard Strip Width	Variable
Standard Strip Length	max. 3,800 mm
Standard Strip Thickness	28 or 34 mm

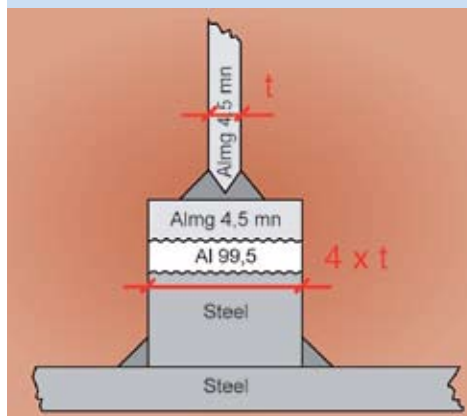



bonding jet. For this reason, less violent explosives can be used for bonding and this, in turn, produces a smoother wave bond between the aluminium and steel which is often barely visible. A turbulent wave motion can trap oxides, resulting in 'holes' being visible in the bond zone. These are in fact, undesirable agglomerations of oxides. Oxide agglomerations are visible with the naked eye. If this product is subjected to the hammer bend test according to MIL J24445A it can be seen that the fractures initiate at these points. Vacuum clad products do not have this problem.

Cost Reduction

A second advantage is the cost reduction in the quantity of explosives needed and the reduced wear of saw blades due to the absence of abrasive oxides in the bond area. Additionally, the fact that favourable weather conditions and long transport routes to isolated cladding sites are not required, gives the vacuum process an advantage. It is therefore apparent that in spite of the initial investment required for a vacuum chamber the cost is cheaper than atmospheric cladding. One must not under-estimate the negative effects of the weather, as temperature and humidity can have a negative influence on the quality of the bond. Thus, vacuum cladding can only be advantageous due to the constantly reproducible and controllable processing conditions. The fear by some potential users that the clad bond produced by vacuum cladding, is inferior due to it being virtually invisible is shown to be unfounded in

practice where outstanding mechanical properties, ductility and fatigue characteristics are encountered. The bond of aluminium to steel does not take place due to the interlocking effect of waves (mechanical), but by an atomic bond of the metals.

Atmospheric Clad Transition Joint

The fracture in a tensile test sample is not at the joint itself, but within the aluminium transition zone. If a sample is exposed to one million cycles of mechanical loading, e.g. a fatigue test then the test sample breaks in the same zone. These facts have resulted in the largest offshore oil company in Norway specifying Triplate for critical components on platforms due to its superior properties. Triplate has also been granted approval by Lloyd's Register, Germanische Lloyd, RINA, Det Norske Veritas, American Bureau of Shipping and Bureau Veritas.

Sandwich of Metals

Triplate consists of a sandwich of three metals namely steel St. 52-3N as base material, aluminium 99.5 (Alloy 1050A) as intermediate layer and the corrosion resistant aluminium alloy AlMg4.5Mn (Alloy 5083) as the upper layer. It is not possible to weld aluminium directly to steel using conventional fusion welding processes, but by using intermediate strips of Triplate pre-bonded cold via the explosion cladding process, high strength aluminium to steel joints can be achieved using conventional fusion welding processes.

Triplate can be produced to various strip widths, but via water jet cutting it is also possible to produce transition pieces to follow complex contours of superstructures. It is obvious that the use of Triplate in this way can have a positive effect on manufacturing costs. Triplate can be cut to length using circular saws or band saws followed by de-burring with an abrasive disc or strip. Triplate strip should never be cut to length using thermal cutting equipment. Horizontal or side-bends can be made in Triplate without problems for a minimum bend radius of ten times the strip width. Vertical bends with the aluminium under tension or compression should be limited to a minimum bending radius of 300 mm in both cases.

Critical Temperatures

The greatest limitation for the combination aluminium/steel is temperature. Above 315°C undesirable intermetallic compounds occur in the transition zone in the form of aluminium/iron crystals (AlFe₃). These brittle compounds adversely affect the mechanical and electrical properties to a high degree. Thus it is very important that the transition strips are not pre-heated prior to welding as this would only increase the temperature of the aluminium/steel zone during welding. The dimensions of the transition strips are calculated so that no embrittlement can be produced during normal welding procedures by considering the temperature gradients in the individual metals. The high thermal conductivity of aluminium

Butt Welds

The strip ends should be chamfered and the butted strips clamped. An area of 3 mm above and below the Aluminium/Steel interface should not be welded. This unwelded area should be hammered watertight or drilled and injected with epoxy or sealant.

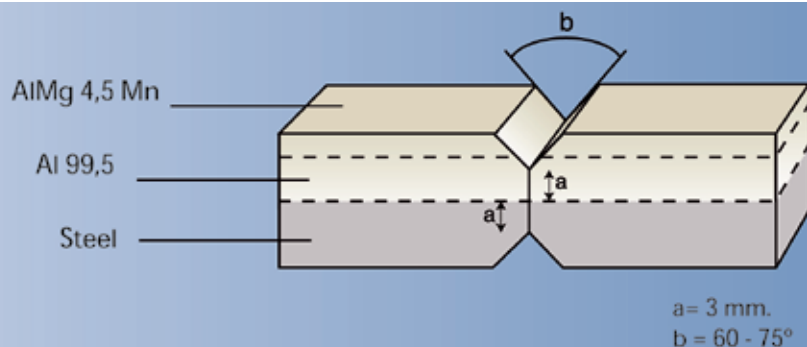

Comparative Properties of Atmospheric and Vacuum Clad Products

Atmospheric	Vacuum
Coarse oxide agglomerations with porosity at the steel-aluminium interface.	100% dense, homogeneous joint.
Oxide agglomerations & porosity initiate fracture.	Does not apply.
Oxide agglomerations & porosity can eventually cause corrosion, in spite of protective coatings.	Does not apply.
Bending of aluminium-steel strips can be difficult due to the coarse bond.	Very good formability due to ductile aluminium-steel joint.
Production control is limited by variable weather conditions.	Optimal process control due to constantly reproducible vacuum conditions.
Aluminium-steel joint is hard, making sawing and forming difficult.	Easy sawing and forming thanks to ductile aluminium-steel joint.

helps to make this possible. Therefore it is important to first weld the aluminium to the Triplate, followed by the steel. To achieve a good control of the heat input in the Triplate, a transition strip width of four times the aluminium superstructure plate thickness should be chosen.

Butt Welds

To avoid gaps between the ends of the individual transition strips, a butt weld joint can be made. The remaining unwelded central gap can be closed either by hammering with a dome-headed hammer or by filling it with a silicone based putty. In order to be completely certain that no part of the transition zone

exceeds the critical temperature of 315°C, it is possible in some circumstances to close the gap without welding, using only hammering or only silicone putty. Moreover, it is often possible to accept some very localized formation of undesirable intermetallic compounds during welding, as these small areas do not have a harmful effect on the whole construction. Above all, the temperature excursions are so short that the undesirable phases do not have time to form. Butt welding the transition strips together also gives a greater structural stability and stiffness to the aluminium superstructure than using 100% putty sealing techniques.

Coating

All conventional marine coatings to prevent contact with sea water can be used on Triplate. Good corrosion results have also been achieved on non-coated constructions due to the fact that with Triplate no natural crevice is present as is the case with bolted or riveted joints. The crevice effect is even further increased in a riveted construction due to the different thermal expansion coefficients which accelerate the capillary effect. In all cases it is recommended to apply the same coating to the Triplate as used on the whole construction.

Thermal Expansion Coefficient

As aluminium and steel have widely differing thermal expansion coefficients, 23×10^{-6} and 12×10^{-6} respectively, one asks the question how this manifests itself in practice. One could imagine that the strip would bend like a bimetal strip when exposed to temperature changes. However the strip remains straight even during appreciable temperature changes. During a temperature change of for instance 40°C, a compressive stress of 33.6 N/mm² is produced in the aluminium and this is totally acceptable for this material.

Conclusion

Aluminium-steel transition joints produced by explosive bonding in air will show the undesirable, crack-initiating holes and oxide agglomerations as red indications when subjected to the dye-penetrant examination. This will not be the case in the vacuum clad product, Triplate.

i. www.triplate.com

*Ko Buijs,
Metallurgical Consultant SMT-Metals Holland.*



Photo courtesy of Aker Solutions